



# Half Brick, DC-DC Converters

**VI-J00**  
**VE-J00**



25 to 100 Watts

## Features & Benefits

- Isolated output
- Up to 50W/in<sup>3</sup>
- cURus, cTUVus
- CE Marked
- Up to 90% efficiency
- Size: 2.28" x 2.4" x 0.5"  
(57,9 x 61,0 x 12,7mm)
- Remote sense and current limit
- Logic disable
- Wide range output adjust
- ZCS power architecture
- Low noise FM control
- RoHS compliant (VE versions)

## Product Highlights

The VI-J00 MiniMod family established a new standard in component-level DC-DC converters. This "junior" size complement to the higher power VI-200 family offers up to 100W of isolated and regulated power in a board mounted package. With thousands of input/output/power combinations, and with a maximum operating temperature rating of 100°C, the MiniMod provides nearly unlimited flexibility for power system designers to meet demanding time to market requirements.

Utilizing Vicor's "zero-current-switching" forward converter technology, proven by an installed base of over 8 million units, the MiniMod family combines state of the art power density with the efficiency, low noise and reliability required by next generation power systems.

## Part Numbering

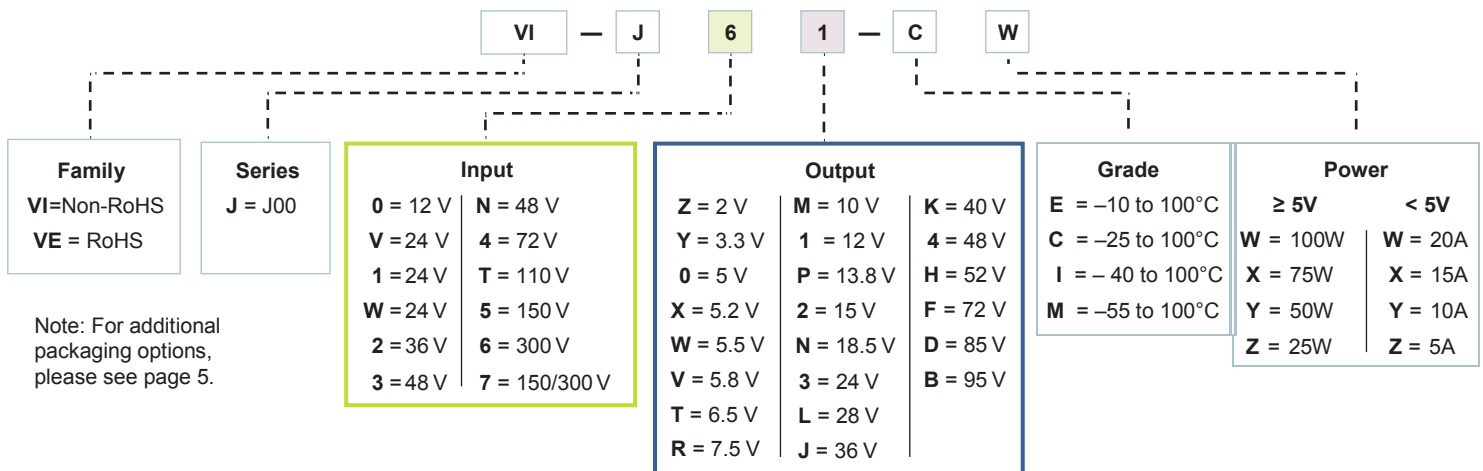

Maximum Power Available for VI-Jxx-xx

Input				Output																					
Voltage Nom. (Range)	Low Line 75% Max Power	Transient <sup>[a]</sup>	VIN Designators	VOUT Designators																					
				2	3.3	5	5.2	5.5	5.8	6.5	7.5	10	12	13.8	15	18.5	24	28	36	40	48	52	72	85	95
				Z	Y	O	X	W	V	T	R	M	1	P	2	N	3	L	J	K	4	H	F	D	B
12 (10 - 20)	n/a	22	0	X	X	Y	Y	Y	Y	Y	Y	X	X	X	X	X	X	X	X	X	X	X	X		
24 (10 - 36)	n/a	n/a	V	--	Y	Y	Y	Y	Y	Y	Y	Y	Y	Y	Y	Y	Y	Y	Y	--	--	--	--		
24 (21 - 32)	18	36	1	W	W	W	W	W	W	X	X	W	W	W	W	W	W	W	W	W	W	W	W		
24 (18 - 36)	n/a	n/a	W	W	W	W	W	W	W	X	X	W	W	W	W	W	W	W	W	W	W	W	W		
36 (21 - 56)	18	60	2	Y	Y	Y	Y	Y	Y	Y	Y	X	X	X	X	X	X	X	X	X	--	--	--		
48 (42 - 60)	36	72	3	W	W	W	W	W	W	X	X	W	W	W	W	W	W	W	W	W	W	W	W		
48 (36 - 76)	n/a	n/a	N	W	W	X	X	X	X	X	X	W	W	W	W	W	W	W	W	W	W	W	W		
72 (55 - 100)	45	110	4	W	W	W	W	W	W	X	X	W	W	W	W	W	W	W	W	W	W	W	W		
110 (66 - 160)	n/a	n/a	T	W	W	X	X	X	X	X	X	W	W	W	W	W	W	W	W	W	W	--	--		
150 (100 - 200)	85	215	5	W	W	W	W	W	W	X	X	W	W	W	W	W	W	W	W	W	W	W	W		
150 (100 - 375)	n/a	n/a	7	Y	Y	Y	Y	Y	Y	Y	Y	X	X	X	X	X	X	X	X	X	X	--	--		
300 (200 - 400)	170	425	6	W	W	W	W	W	W	X	X	W	W	W	W	W	W	W	W	W	W	W	W		

<sup>[a]</sup> Transient voltage for 1 second.

Converter Specifications (typical at TBP = 25°C, nominal line and 75% load, unless otherwise specified)

INPUT SPECIFICATIONS

Parameter	VI-200 E-Grade			VI-200 C-, I-, M-Grade			Units	Test Conditions
	Min	Typ	Max	Min	Typ	Max		
Inrush charge		60 x 10 <sup>-6</sup>			60 x 10 <sup>-6</sup>	100 x 10 <sup>-6</sup>	Coulombs	Nominal line
Input reflected ripple current – pp		10%			10%		I <sub>IN</sub>	Nominal line, full load
Input ripple rejection		25+20 Log ( $\frac{V_{O(NT)}$ )			30+20 Log ( $\sqrt{V_{IN}}$ )		dB	120Hz, nominal line
					20+20 Log ( $\sqrt{V_{IN}}$ )			2400Hz, nominal line
No load power dissipation		1.35	2		1.35	2	Watts	

## Converter Specifications (Cont.)

## OUTPUT CHARACTERISTICS

Parameter	VI-200 E-Grade			VI-200 C-, I-, M-Grade			Units	Test Conditions
	Min	Typ	Max	Min	Typ	Max		
Setpoint accuracy		1%	2%		0.5%	1%	V <sub>NOM</sub>	
Load/line regulation			0.5%		0.05%	0.2%	V <sub>NOM</sub>	LL to HL, 10% to Full Load
Load/line regulation			1%		0.2%	0.5%	V <sub>NOM</sub>	LL to HL, No Load to 10%
Output temperature drift		0.02			0.01	0.02	% / °C	Over rated temp.
Long term drift		0.02			0.02		%/1K hours	
Output ripple – pp: 2V, 3.3V			200		100	150	mV	20MHz bandwidth
5V			5%		2%	3%	V <sub>NOM</sub>	20MHz bandwidth
10 – 95V			3%		0.75%	1.5%	V <sub>NOM</sub>	20MHz bandwidth
Trim range <sup>[a]</sup>	50%		110%	50%		110%	V <sub>NOM</sub>	
Total remote sense compensation	0.5			0.5			Volts	0.25V max. neg. leg
Current limit	105%		135%	105%		125%	I <sub>FULL LOAD</sub>	Automatic restart
Short circuit current	105%		140%	105%		130%	I <sub>FULL LOAD</sub>	Automatic restart

<sup>[a]</sup> 10V to 15V outputs, or “V” input range have standard trim range ±10%. Consult factory for wider trim range.  
95V output –50 + 0% trim range.

## CONTROL PIN SPECIFICATIONS

Parameter	VI-200 E-Grade			VI-200 C-, I-, M-Grade			Units	Test Conditions
	Min	Typ	Max	Min	Typ	Max		
Gate out impedance		50			50		Ohms	
Gate in impedance		1000			1000		Ohms	
Gate in high threshold		6				6	Volts	Use open collector
Gate in low threshold	0.65			0.65			Volts	
Gate in low current			6			6	mA	

## Converter Specifications (Cont.)

### DIELECTRIC WITHSTAND CHARACTERISTICS

Parameter	VI-200 E-Grade			VI-200 C-, I-, M-Grade			Units	Test Conditions
	Min	Typ	Max	Min	Typ	Max		
Input to output	3,000			3,000			V <sub>RMS</sub>	Baseplate earthed
Output to baseplate	500			500			V <sub>RMS</sub>	
Input to baseplate	1,500			1,500			V <sub>RMS</sub>	

### THERMAL CHARACTERISTICS

Parameter	VI-200 E-Grade			VI-200 C-, I-, M-Grade			Units	Test Conditions
	Min	Typ	Max	Min	Typ	Max		
Efficiency		78 – 88%			80 – 90%			
Baseplate to sink		0.14			0.14		°C/Watt	With Vicor P/N 20267

<sup>[d]</sup> No overtemp protection in booster modules.

### MECHANICAL SPECIFICATIONS

Parameter	VI-200 E-Grade			VI-200 C-, I-, M-Grade			Units	Test Conditions
	Min	Typ	Max	Min	Typ	Max		
Weight	2.9 (82.8)	3.2 (92)	3.6 (101.2)	3.4 (96.3)	3.8 (107)	4.1 (117.7)	Ounces (Grams)	

### PRODUCT GRADE TEMPERATURES

Parameter	Storage	Operating	Units	Notes
E	-20 to +105	-10 to + 100	°C	
C	-40 to +105	-25 to + 100	°C	
I	-55 to +105	-40 to + 100	°C	
M	-65 to +105	-55 to + 100	°C	

Mechanical Drawing

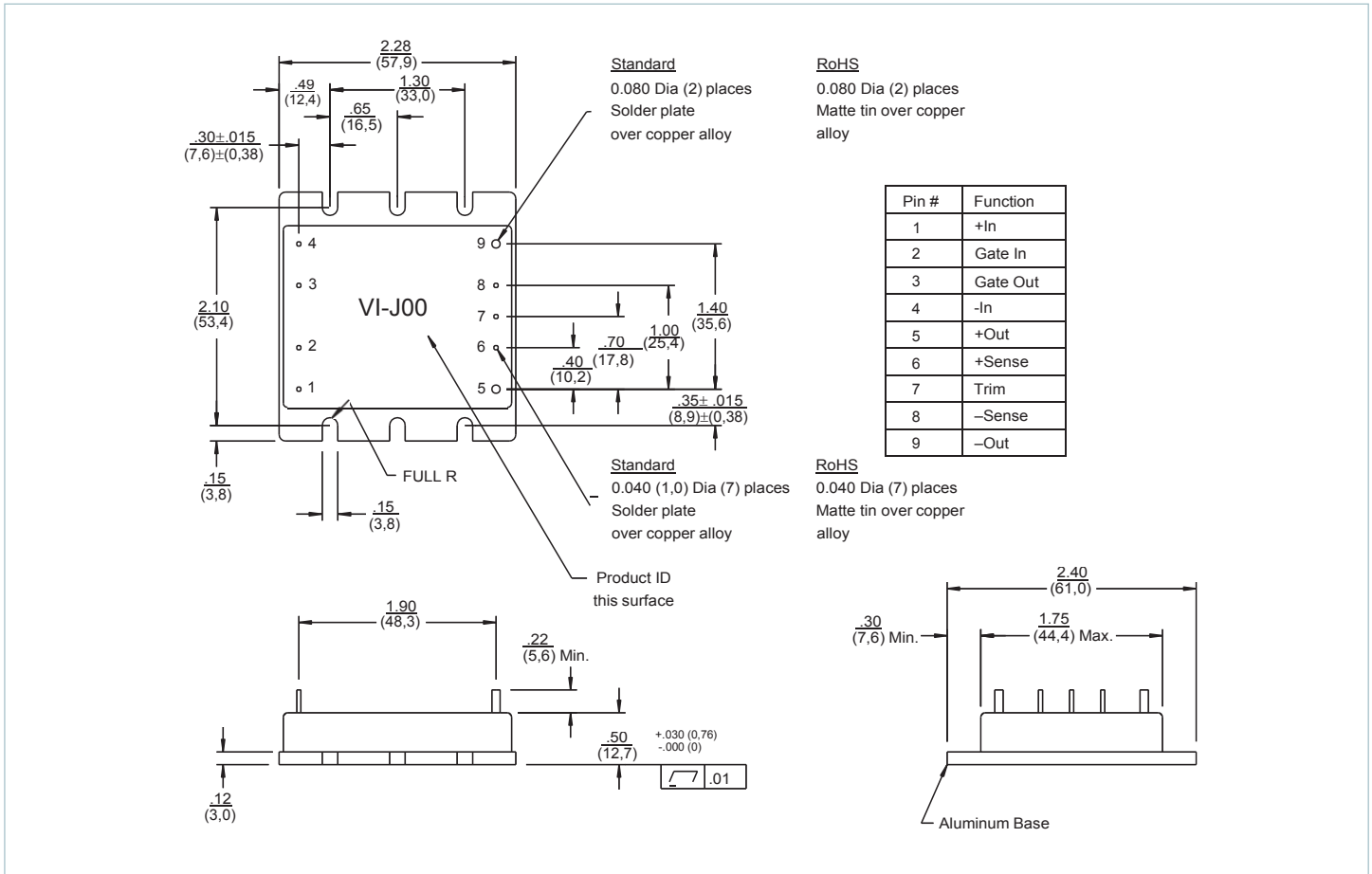

PACKAGING OPTIONS

Flangeless package



2.28" L x 1.80" W x 0.50" H  
(57,9 x 45,7 x 12,7mm)

To order the SlimMod configuration add the suffix "- S" to the standard module part number.

Qty (2) grounding clips are included with each SlimMod P/N 32187

Flangeless package with integral heat sink



Longitudinal, 0.25"(6.35mm) fins — add suffix "- F1"  
Longitudinal, 0.50"(12.7mm) fins — add suffix "- F2"



Transverse, 0.25"(6.35mm) fins — add suffix "- F3"  
Transverse, 0.50"(12.7mm) fins — add suffix "- F4"

Available with longitudinal or transverse fins of 0.25"(6.35mm) or 0.50"(12.7mm) height. Add the appropriate suffix to the module part number.

Qty (4) grounding clips are included with each FinMod  
F1, F2 P/N 32185  
F3, F4 P/N 32186

MegaMod Jr.

Chassis mount alternatives, one, two, or three outputs: up to 300W



1 up — 2.58" x 2.5" x 0.62" (65,5 x 63,5 x 15,7mm)  
2 up — 2.58" x 4.9" x 0.62" (65,5 x 124,5 x 15,7mm)  
3 up — 2.58" x 7.3" x 0.62" (65,5 x 185,4 x 15,7mm)

BusMod



2.28" L x 2.40" W x 1.08" H  
(57,9 x 61,0 x 27,4mm)

To order the BusMod fully assembled, add suffix "-B1" to the standard module part number.

To order the BusMod separately:  
Half-sized BusMod — P/N 18952

See BusMod Mechanical Drawings for more details.

**Vicor's comprehensive line of power solutions includes high density AC-DC and DC-DC modules and accessory components, fully configurable AC-DC and DC-DC power supplies, and complete custom power systems.**

Information furnished by Vicor is believed to be accurate and reliable. However, no responsibility is assumed by Vicor for its use. Vicor makes no representations or warranties with respect to the accuracy or completeness of the contents of this publication. Vicor reserves the right to make changes to any products, specifications, and product descriptions at any time without notice. Information published by Vicor has been checked and is believed to be accurate at the time it was printed; however, Vicor assumes no responsibility for inaccuracies. Testing and other quality controls are used to the extent Vicor deems necessary to support Vicor's product warranty. Except where mandated by government requirements, testing of all parameters of each product is not necessarily performed.

**Specifications are subject to change without notice.**

### **Vicor's Standard Terms and Conditions**

All sales are subject to Vicor's Standard Terms and Conditions of Sale, which are available on Vicor's webpage or upon request.

### **Product Warranty**

In Vicor's standard terms and conditions of sale, Vicor warrants that its products are free from non-conformity to its Standard Specifications (the "Express Limited Warranty"). This warranty is extended only to the original Buyer for the period expiring two (2) years after the date of shipment and is not transferable.

UNLESS OTHERWISE EXPRESSLY STATED IN A WRITTEN SALES AGREEMENT SIGNED BY A DULY AUTHORIZED VICOR SIGNATORY, VICOR DISCLAIMS ALL REPRESENTATIONS, LIABILITIES, AND WARRANTIES OF ANY KIND (WHETHER ARISING BY IMPLICATION OR BY OPERATION OF LAW) WITH RESPECT TO THE PRODUCTS, INCLUDING, WITHOUT LIMITATION, ANY WARRANTIES OR REPRESENTATIONS AS TO MERCHANTABILITY, FITNESS FOR PARTICULAR PURPOSE, INFRINGEMENT OF ANY PATENT, COPYRIGHT, OR OTHER INTELLECTUAL PROPERTY RIGHT, OR ANY OTHER MATTER.

This warranty does not extend to products subjected to misuse, accident, or improper application, maintenance, or storage. Vicor shall not be liable for collateral or consequential damage. Vicor disclaims any and all liability arising out of the application or use of any product or circuit and assumes no liability for applications assistance or buyer product design. Buyers are responsible for their products and applications using Vicor products and components. Prior to using or distributing any products that include Vicor components, buyers should provide adequate design, testing and operating safeguards.

Vicor will repair or replace defective products in accordance with its own best judgment. For service under this warranty, the buyer must contact Vicor to obtain a Return Material Authorization (RMA) number and shipping instructions. Products returned without prior authorization will be returned to the buyer. The buyer will pay all charges incurred in returning the product to the factory. Vicor will pay all reshipment charges if the product was defective within the terms of this warranty.

### **Life Support Policy**

VICOR'S PRODUCTS ARE NOT AUTHORIZED FOR USE AS CRITICAL COMPONENTS IN LIFE SUPPORT DEVICES OR SYSTEMS WITHOUT THE EXPRESS PRIOR WRITTEN APPROVAL OF THE CHIEF EXECUTIVE OFFICER AND GENERAL COUNSEL OF VICOR CORPORATION. As used herein, life support devices or systems are devices which (a) are intended for surgical implant into the body, or (b) support or sustain life and whose failure to perform when properly used in accordance with instructions for use provided in the labeling can be reasonably expected to result in a significant injury to the user. A critical component is any component in a life support device or system whose failure to perform can be reasonably expected to cause the failure of the life support device or system or to affect its safety or effectiveness. Per Vicor Terms and Conditions of Sale, the user of Vicor products and components in life support applications assumes all risks of such use and indemnifies Vicor against all liability and damages.

### **Intellectual Property Notice**

Vicor and its subsidiaries own Intellectual Property (including issued U.S. and Foreign Patents and pending patent applications) relating to the products described in this data sheet. No license, whether express, implied, or arising by estoppel or otherwise, to any intellectual property rights is granted by this document. Interested parties should contact Vicor's Intellectual Property Department.